

The background is a solid teal color with several large, overlapping, rounded rectangular shapes in a slightly darker shade of teal, creating a layered, abstract effect.

 **ERO**

The logo icon is a white square with rounded corners containing three teal diagonal lines of varying lengths, slanted from the top-left to the bottom-right. To the right of the icon, the word "ERO" is written in a bold, white, sans-serif font.



Geologia E Controle Estrutural Das Mineralizações De Cu-Ni Mina Vermelhos, Norte Do Vale Do Curaçá

Cotias, F. A.; Oliveira, E. L. C.; Desrochers, J. P. ; Rocha, M .R.; Freire, M. M.,
Vermelhos Mining Geology and Exploration Team

Agosto, 2025



Caution Regarding Forward Looking Information and Statements

This presentation contains “forward-looking statements” within the meaning of the United States Private Securities Litigation Reform Act of 1995 and “forward-looking information” within the meaning of applicable Canadian securities legislation (collectively, “forward-looking statements”). Forward-looking statements include statements that use forward-looking terminology such as “may”, “could”, “would”, “will”, “should”, “intend”, “target”, “plan”, “expect”, “budget”, “estimate”, “forecast”, “schedule”, “anticipate”, “believe”, “continue”, “potential”, “view” or the negative or grammatical variation thereof or other variations thereof or comparable terminology. Forward-looking statements include, but are not limited to, statements with respect to the management’s assessment of Mineral Resource and Mineral Reserve estimates, the capital and operating cost estimates and the economic analyses (including cash flow projections) for the Vale do Curaçá property, NX Gold Mine and the Boa Esperança property, future financial or operating performance and condition of the Company and its business, operations and properties, plans for the operation of MCSA, costs and estimates for timing of expenditures related to development of any mill expansions, timing of any catalysts including expected release of updated mine plans, benefit of any cost reduction initiative, proposed benefit of recovery optimization projects, the continued development of the Curaçá Valley and future development of the Boa Esperança project, the development of potential mineral resources, expansion of production through the Caraíba Mill, future exploration potential, usefulness of the airborne EM survey, conversion of mineral resources, the effectiveness of any measure put in place by the Company to mitigate the impact of COVID-19 on the Company or its operations and any future exploration plans including further delineation of near-mine and district exploration targets.

Forward-looking statements are not a guarantee of future performance and are based upon a number of estimates and assumptions of management in light of management’s experience and perception of trends, current conditions and expected developments, as well as other factors that management believes to be relevant and reasonable in the circumstances, as of the date of this presentation including, without limitation, assumptions about: favourable equity and debt capital markets; the ability to raise any necessary additional capital on reasonable terms to advance the production, development and exploration of the Company’s properties and assets; future prices of copper and other metal prices; the timing and results of exploration and drilling programs; the accuracy of any Mineral Reserve and Mineral Resource estimates; the geology of the Vale do Curaçá Property, the NX Gold Mine and the Boa Esperança Property being as described in the Vale do Curaçá Technical Report and the Boa Esperança Technical Report, respectively; production costs; the accuracy of budgeted exploration and development costs and expenditures; the price of other commodities such as fuel; future currency exchange rates and interest rates; operating conditions being favourable such that the Company is able to operate in a safe, efficient and effective manner; political and regulatory stability; the receipt of governmental, regulatory and third party approvals, licenses and permits on favourable terms; obtaining required renewals for existing approvals, licenses and permits on favourable terms; requirements under applicable laws; sustained labour stability; stability in financial and capital goods markets; availability of equipment; positive relations with local groups and the Company’s ability to meet its obligations under its agreements with such groups; and satisfying the terms and conditions of the Company’s current loan arrangements. While the Company considers these assumptions to be reasonable, the assumptions are inherently subject to significant business, social, economic, political, regulatory, competitive and other risks and uncertainties, contingencies and other factors that could cause actual actions, events, conditions, results, performance or achievements to be materially different from those projected in the forward-looking statements. Many assumptions are based on factors and events that are not within the control of the Company and there is no assurance they will prove to be correct.

Furthermore, such forward-looking statements are subject to known and unknown risks, uncertainties and other factors that may cause the actual results, level of activity, performance or achievements of the Company to be materially different from those expressed or implied by such forward-looking statements, including but not limited to: risks related to general economic conditions, political conditions in Canada and Brazil, risks related to international operations, the actual results of current mining and exploration activities, conclusions of economic evaluations, changes in project parameters as plans continue to be refined, future prices of copper, gold and silver, market conditions and the availability of financing for mining companies. There can be no assurance that any forward-looking statements will prove to be accurate, as actual results and future events could differ materially from those anticipated in such statements. Accordingly, readers should not place undue reliance on forward-looking statements. The Company does not undertake to update any forward-looking statements that are included herein, except in accordance with applicable securities laws. See the section titled “Risk Factors” in the Annual Information Form of the Company for the year ended December 31, 2019, dated March 12, 2020 (the “AIF”).

Cautionary Note to U.S Investors Concerning Estimates of Measured, Indicated and Inferred Resources

This presentation uses the terms “Measured”, “Indicated” and “Inferred” Resources. U.S. Investors are advised that while such terms are recognized and required by Canadian regulations, the Securities and Exchange Commission does not recognize them. “Inferred Resources” have a great amount of uncertainty as to their existence, and great uncertainty as to their economic and legal feasibility. It cannot be assumed that all or any part of an Inferred Resource will ever be upgraded to a higher category. Under Canadian rules, estimates of Inferred Resources may not form the basis of feasibility or other economic studies. U.S. Investors are cautioned not to assume that all or any part of Measured or Indicated Resources will ever be converted into reserves. U.S. Investors are also cautioned not to assume that all or any part of an Inferred Resource exists, or is economically or legally mineable.



U.S. Securities Law Disclaimer

The securities of the Company have not been, and will not be, registered under the United States Securities Act of 1933, as amended (the "U.S. Securities Act"), or any state securities laws and, subject to certain exceptions, may not be offered or sold within the United States, as such term is defined in Regulation S under the U.S. Securities Act.

General

Scientific and technical information contained in this presentation has been reviewed and approved by Emerson Ricardo Re, Resource Manager. Mr. Re is an employee of Ero and Qualified Person" as defined by Canadian Securities Administrators' National Instrument 43-101 - Standards of Disclosure for Mineral Projects ("NI 43-101").

Where applicable, information of a scientific or technical nature in respect of the Vale do Curaçá Property included in this presentation is based upon the supplemental technical information provided in the technical report dated November 25, 2019 with an effective date of September 18, 2019 entitled "2019 Updated Mineral Resources and Mineral Reserves Statements of Mineração Caraíba's Vale do Curaçá Mineral Assets, Curaçá Valley", prepared by Rubens Jose De Mendonça, MAusIMM, of Planminas and Porfírio Cabaleiro Rodrigues, MAIG, Leonardo de Moraes Soares, MAIG, and Bernardo Horta de Cerqueira Viana, MAIG, all of GE21 Consultoria Mineral Ltda. ("GE21"), who are independent qualified persons under NI 43-101 (the "2019 Technical Report") , where applicable the technical report dated October 17, 2018 with an effective date of August 1, 2018 entitled "2018 Updated Mineral Resources and Mineral Reserves Statements of Mineração Caraíba's Vale do Curaçá Mineral Assets, Curaçá Valley", prepared by Rubens Jose De Mendonça, MAusIMM, of Planminas and Porfírio Cabaleiro Rodrigues, MAIG, Fábio Valério Câmara Xavier, MAIG, and Bernardo Horta de Cerqueira Viana, MAIG, all of GE21, who are independent qualified persons under NI 43-101 (the "2018 Technical Report") and, where applicable, the technical report, dated September 7, 2017 with an effective date of June 1, 2017, entitled "2017 Updated Mineral Resources and Mineral Reserves Statements of Mineração Caraíba's Vale do Curaçá Mineral Assets, Curaçá Valley", prepared by Rubens Mendonça, MAusIMM, of SRK Brazil (now of Planminas – Projectos e Consultoria em Mineração Ltd.), and Porfírio Cabaleiro Rodrigues, MAIG, Mário Conrado Reinhardt, MAIG, Fábio Valério Xavier, MAIG and Bernardo H.C. Viana, MAIG, all of GE21, who are independent qualified persons under NI 43-101 (the "2017 Technical Report"), collectively referred to herein as the "Technical Reports".

Information of a scientific or technical nature in respect of the NX Gold Mine included in this presentation is based on upon the technical report, dated February 3, 2020 with an effective date of September 30, 2019, entitled "Mineral Resource and Reserve Estimate of the NX Gold Mine, Nova Xavantina", prepared by Porfírio Cabaleiro Rodriguez, MAIG, Paulo Roberto Begmann, FAusIMM and Leonardo de Moraes Soares, MAIG, all of GE21 Consultoria Mineral Ltda., who are independent qualified persons under NI 43-101 (the "NX Gold Mine Technical Report"). Information of a scientific or technical nature in respect of the Boa Esperança Property included in this presentation is based upon the technical report, dated September 7, 2017 with an effective date of June 1, 2017, entitled "Feasibility Study Technical Report for the Boa Esperança Copper Project, Pará State, Brazil", prepared by Carlos Barbosa, MAIG, Rubens Mendonça, MAusIMM and Girogio di Tomi, MAusIMM, all of SRK Brazil, who are independent qualified persons under NI 43-101 (the "Boa Esperança Technical Report").

Please see the AIF, the Technical Reports, the NX Gold Mine Technical Report and the Boa Esperança Technical Report, each filed on the Company's profile at www.sedar.com, for details regarding the data verification undertaken with respect to the scientific and technical information included in this presentation regarding the Vale do Curaçá Property, the NX Gold Mine and the Boa Esperança Property, for additional details regarding the related exploration information, including interpretations, the QA/QC employed, sample, analytical and testing results and for additional details regarding the Mineral Resource and Mineral Reserve estimates disclosed herein.

Mineral resources shown within the three-dimensional ("3D") model portion of this presentation are as outlined in the 2019 Technical Report. Mineral resources shown inclusive of mineral reserves. Mineral resources which are not mineral reserves do not have demonstrated economic viability. For additional information about the current mineral resources and reserves of these zones please refer to the 2019 Technical Report. Drill hole information including mineralized intercepts shown within the 3D model portion of this presentation is as outlined in the Company's news releases published on the Company's website (www.ero-copper.com) and on SEDAR (www.sedar.com).

Where applicable, exploration target projection(s) are shown to demonstrate future area of exploration focus within the Company's operations. These projections are based on data compilation work which includes review of geological controls, structural analysis and copper mineralization identified during the Company's technical programs. The interpretation and boundary limits do not imply continuity of mineralization, or actual thickness of mineralization which has yet to be defined.

Third Party Information

This presentation includes market, industry and economic data which was obtained from various publicly available sources and other sources believed by the Company to be true. Although the Company believes it to be reliable, the Company has not independently verified any of the data from third party sources referred to in this presentation, or analyzed or verified the underlying reports relied upon or referred to by such sources, or ascertained the underlying economic and other assumptions relied upon by such sources. The Company believes that its market, industry and economic data is accurate and that its estimates and assumptions are reasonable, but there can be no assurance as to the accuracy or completeness thereof. The accuracy and completeness of the market, industry and economic data used throughout this presentation are not guaranteed and the Company does not make any representation as to the accuracy or completeness of such information.

Non-IFRS Measures

Financial results of the Company and MCSA are prepared in accordance with IFRS. The Company and MCSA utilize certain non-IFRS measures, including C1 cash cost of copper produced per pound, EBITDA and working capital as more particularly described in the Company's MD&A for the three and nine months ended September 30, 2019, a copy of which can be found on the Company's website and on SEDAR. The Company believes that these measures, together with measures determined in accordance with IFRS, provide investors with an improved ability to evaluate the underlying performance of the Company and MCSA. Non-IFRS measures do not have any standardized meaning prescribed under IFRS, and therefore they may not be comparable to similar measures employed by other companies. The data is intended to provide additional information and should not be considered in isolation or as a substitute for measures of performance prepared in accordance with IFRS. C1 cash cost of copper produced (per lb) is the sum of production costs, net of capital expenditure development costs and by-product credits, divided by the copper pounds produced. C1 cash costs reported by the Company include treatment, refining charges, offsite costs, and certain tax credits relating to sales invoiced to the Company's Brazilian customer on sales. By-product credits are calculated based on actual precious metal sales (net of treatment costs) during the period divided by the total pounds of copper produced during the period.

Localização / Geologia Regional

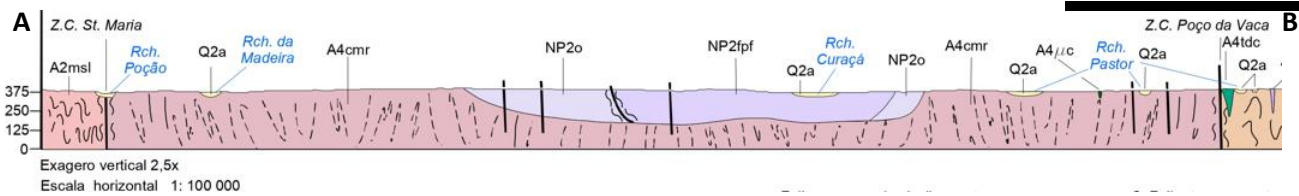
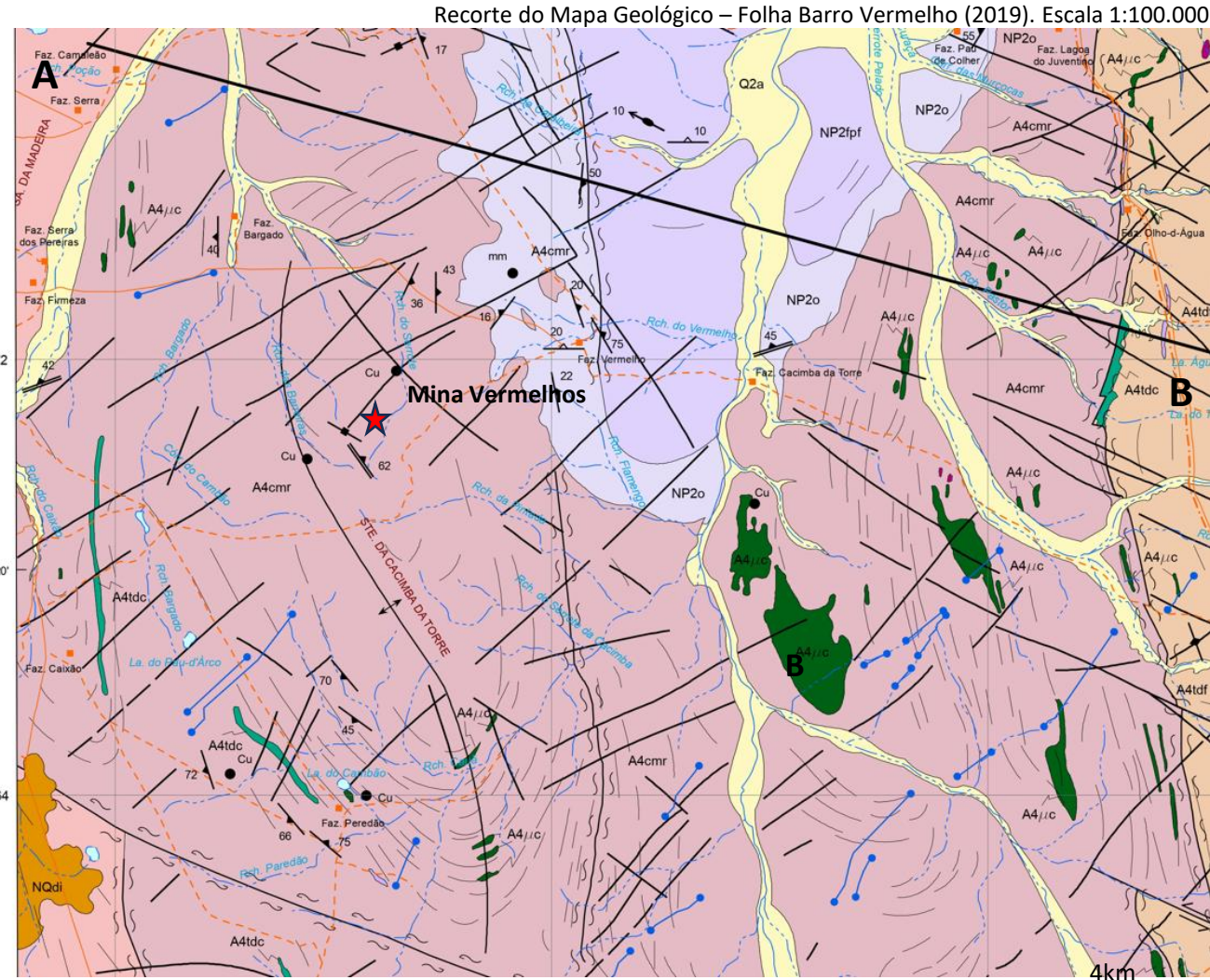
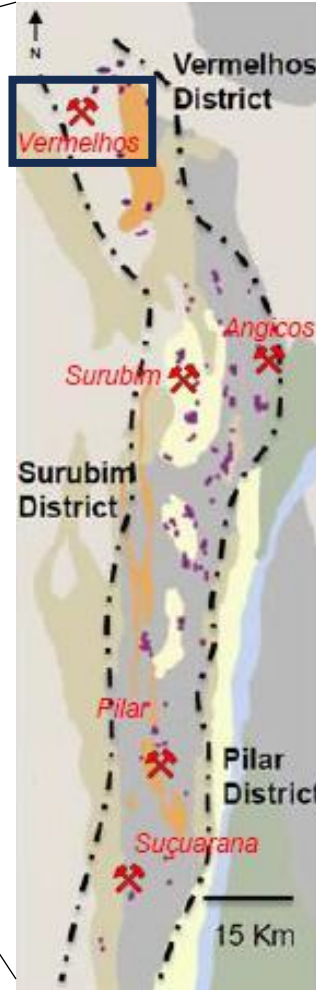
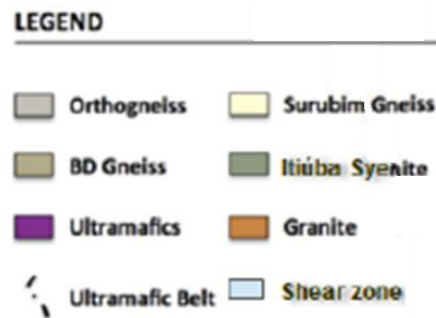
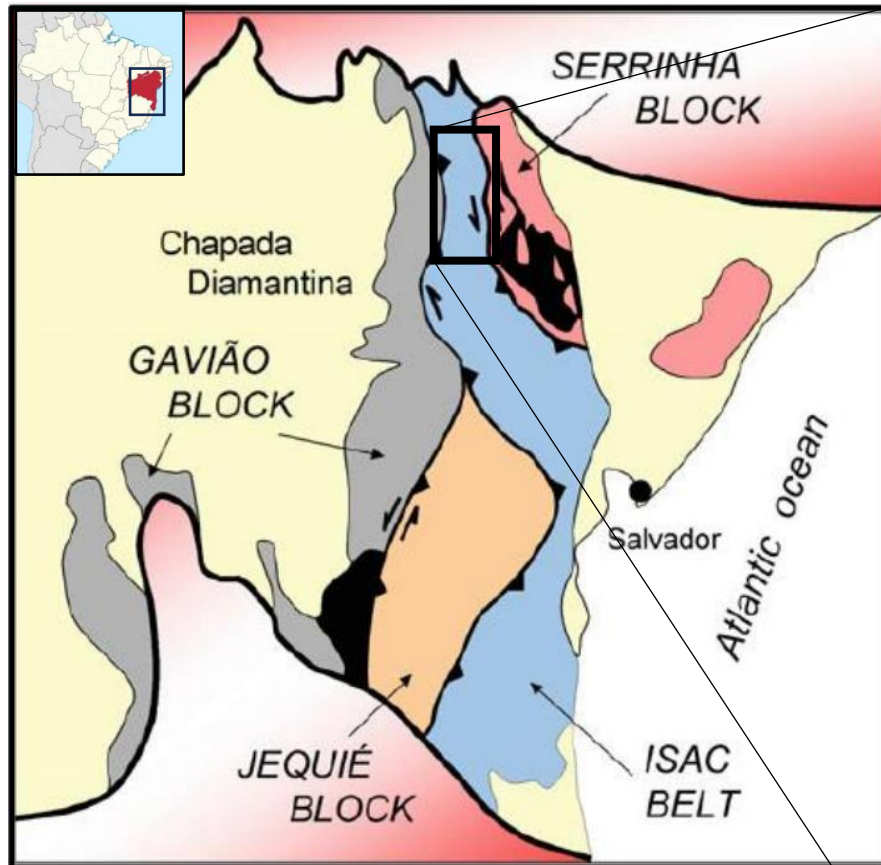

A4/c **Corpos máfico-ultramáficos do Vale do Curaçá:** megabro e anfibolito predominantes, além de norito, metapiroxenito, metahiperstenito e serpentinito, portadores, em parte, de mineralizações cupríferas.

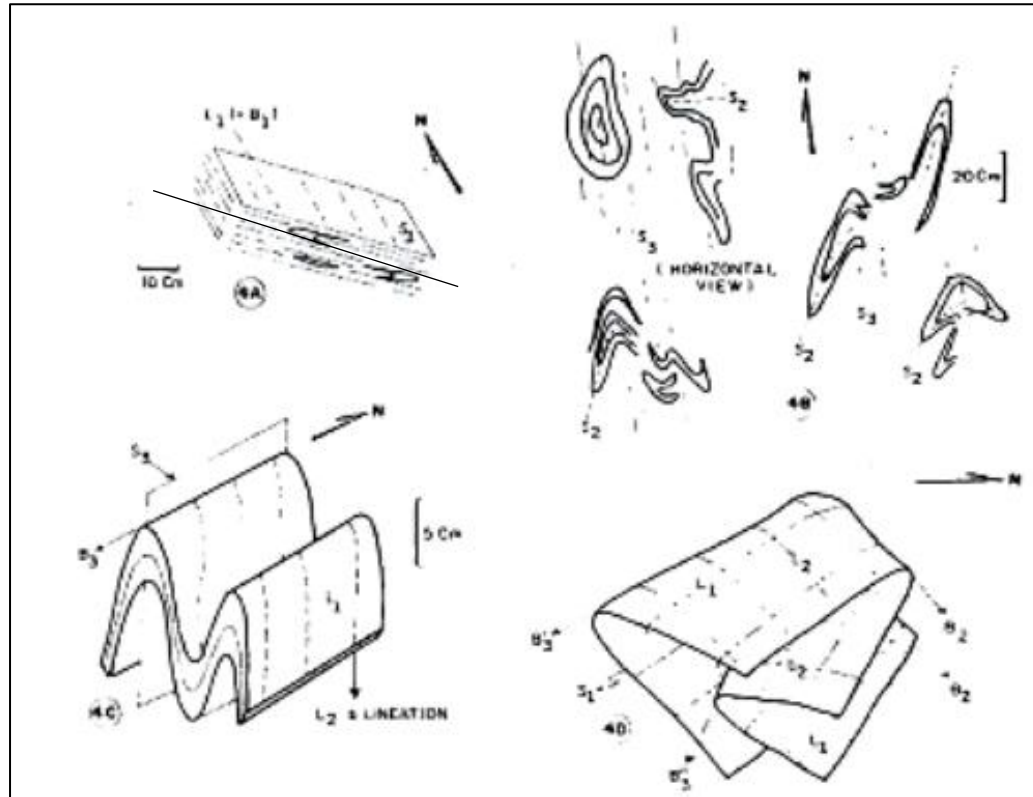

Jardim de Sá (1982)

- D1 -> S0 // S1 // F1
- D2 -> F2 (E-W)
- D3 -> F3 (N-S)
- D4 ?

ESCALAS APROXIMADAS:

1 cm = 200m (Vert.)

1 cm = 100m (Horz.)

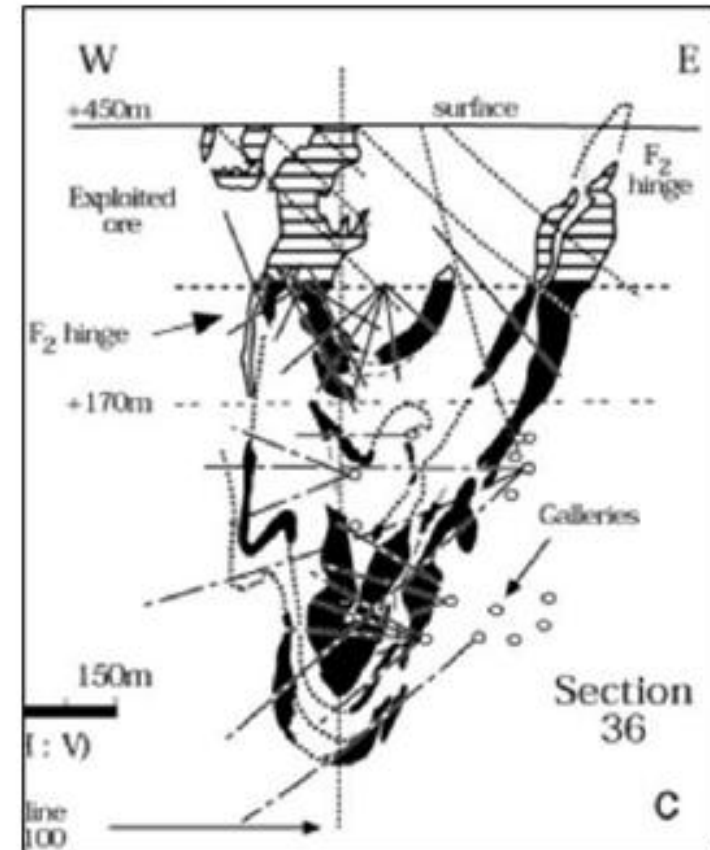

DelRey (1994)

Seção Geológica 797

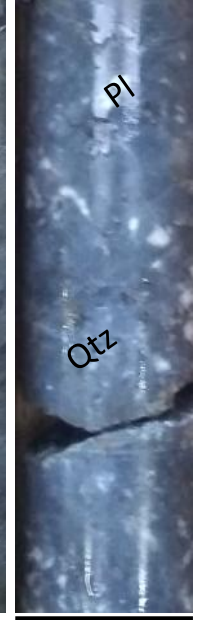
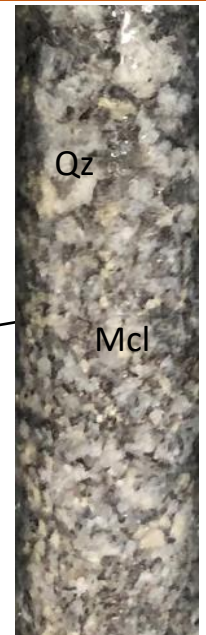
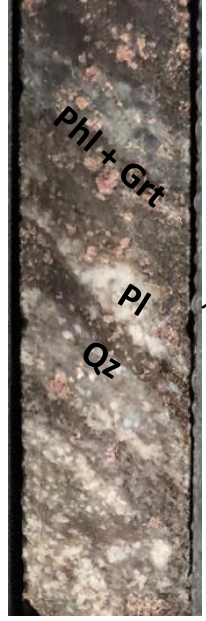
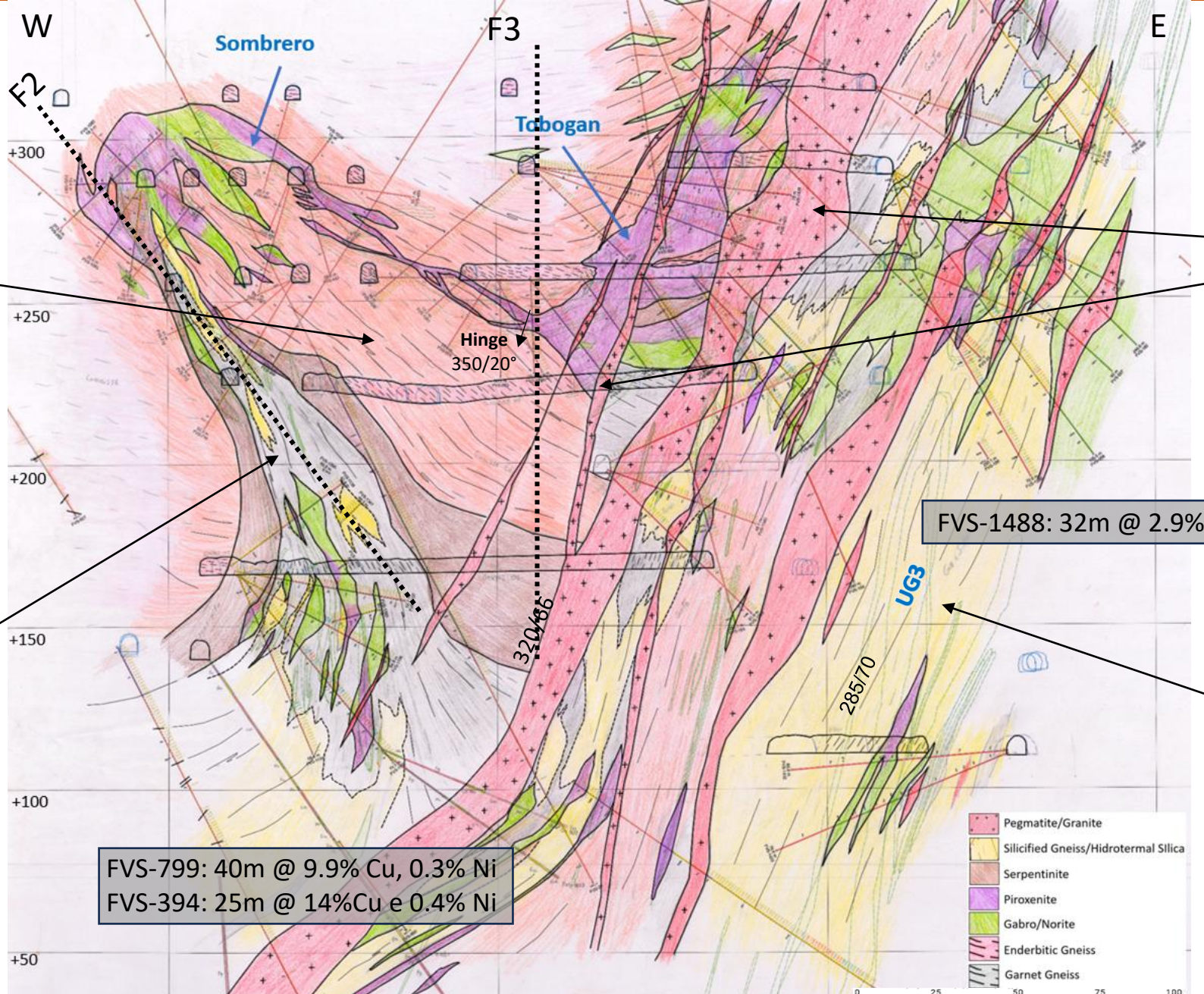

FVS-799: 40m @ 9.9% Cu, 0.3% Ni
 FVS-394: 25m @ 14%Cu e 0.4% Ni

FVS-1488: 32m @ 2.9% Cu

48mm

48mm

Rocha hospedeira e texturas do minério - Tobogan

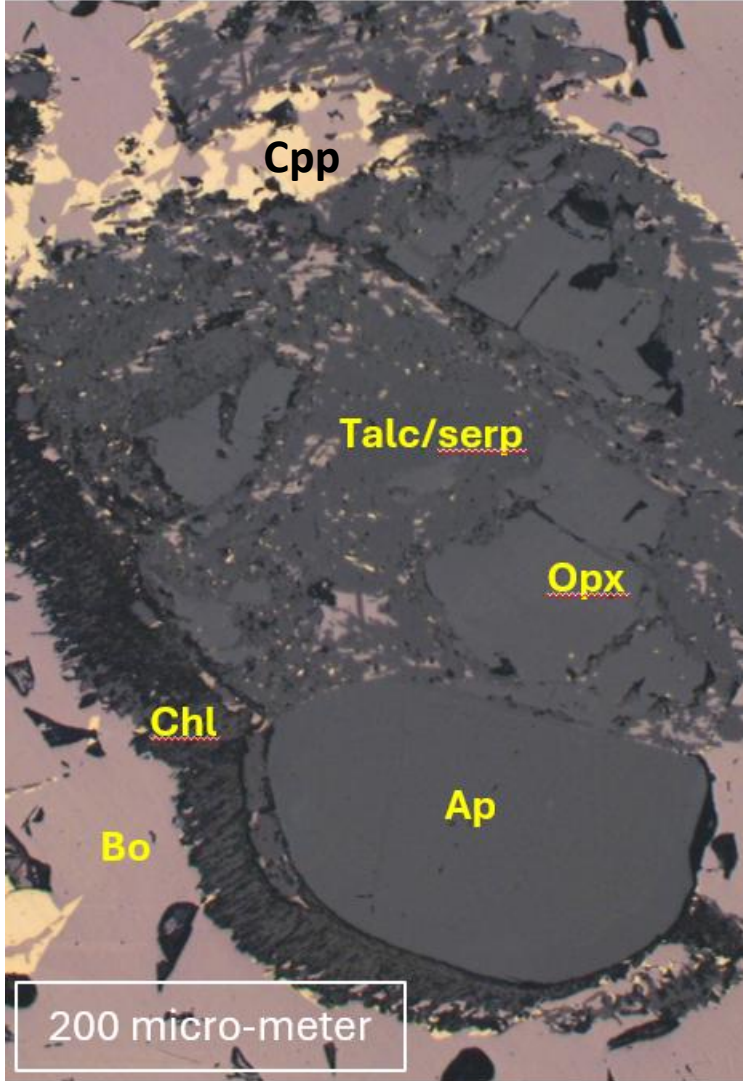

Rocha hospedeira e texturas do minério - Tobogan

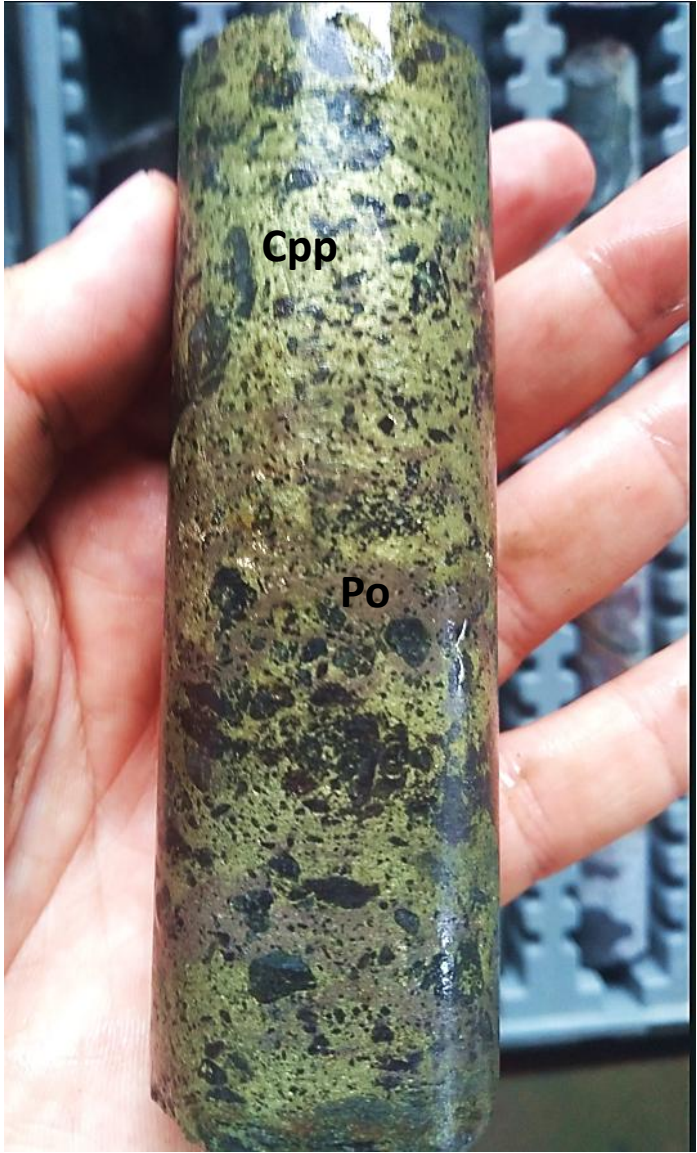





Feições na mina - Intrusões concordantes (Tobogan)

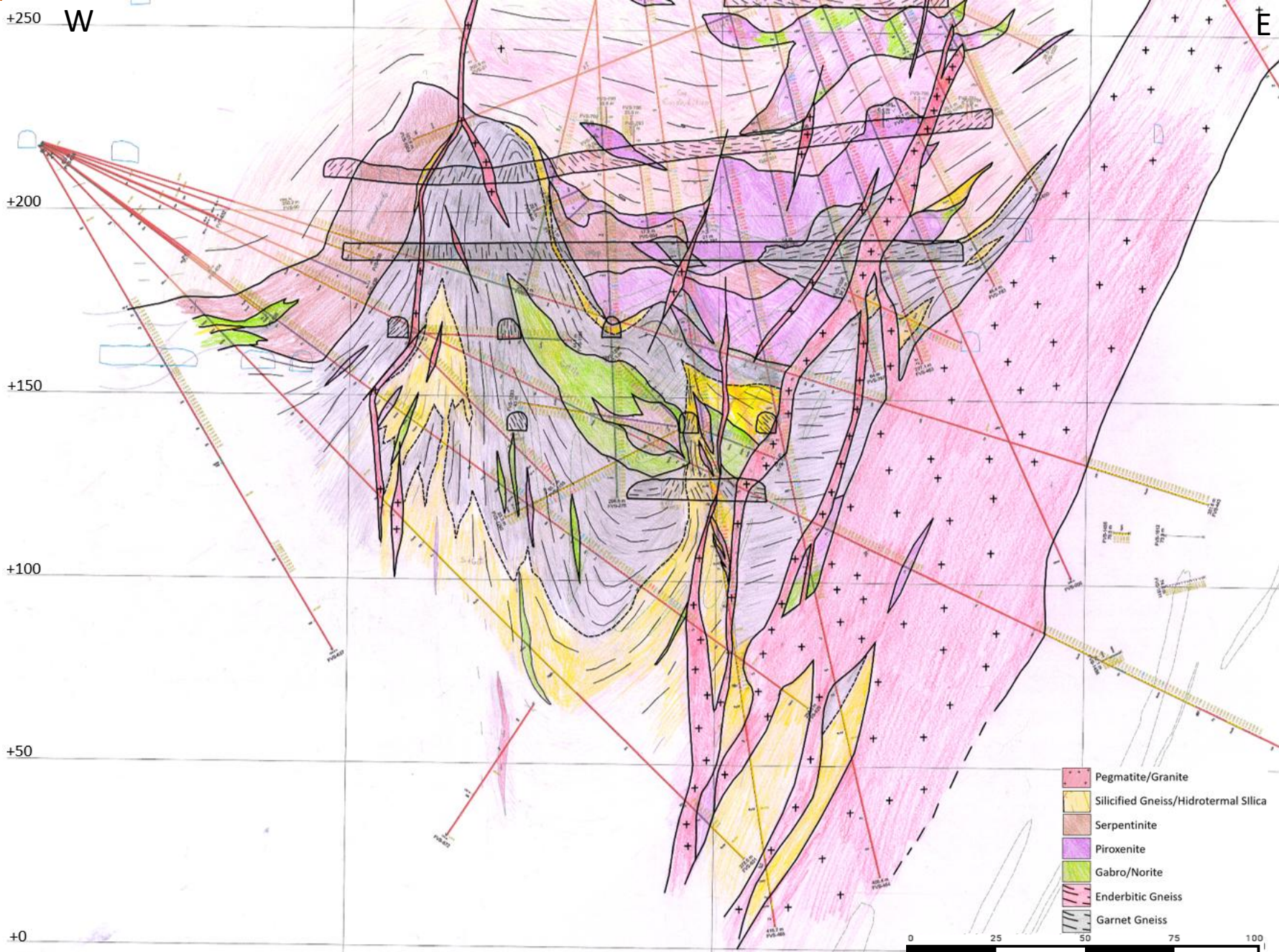

Feições na mina - Intrusões concordantes (Tobogan)

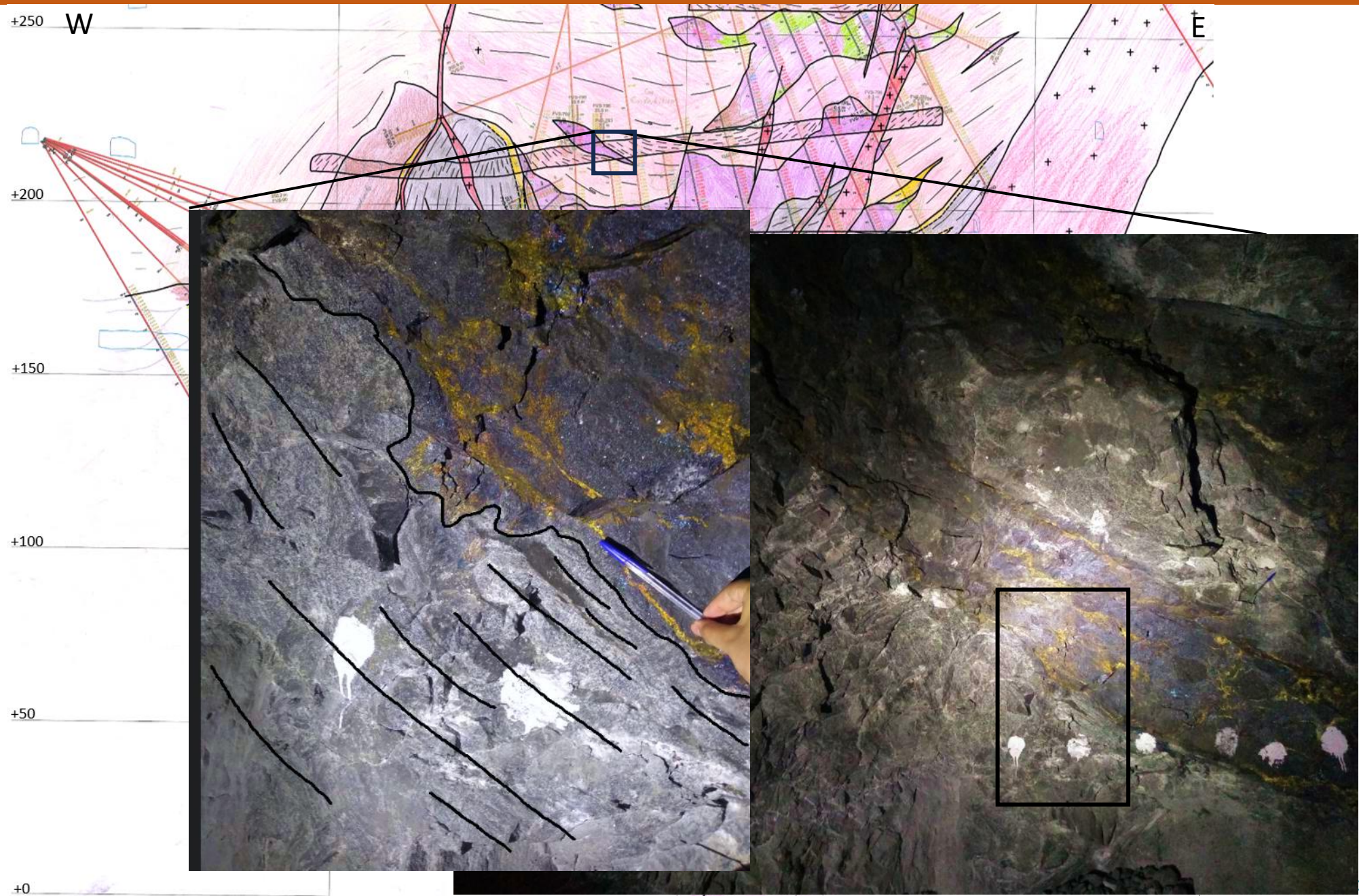

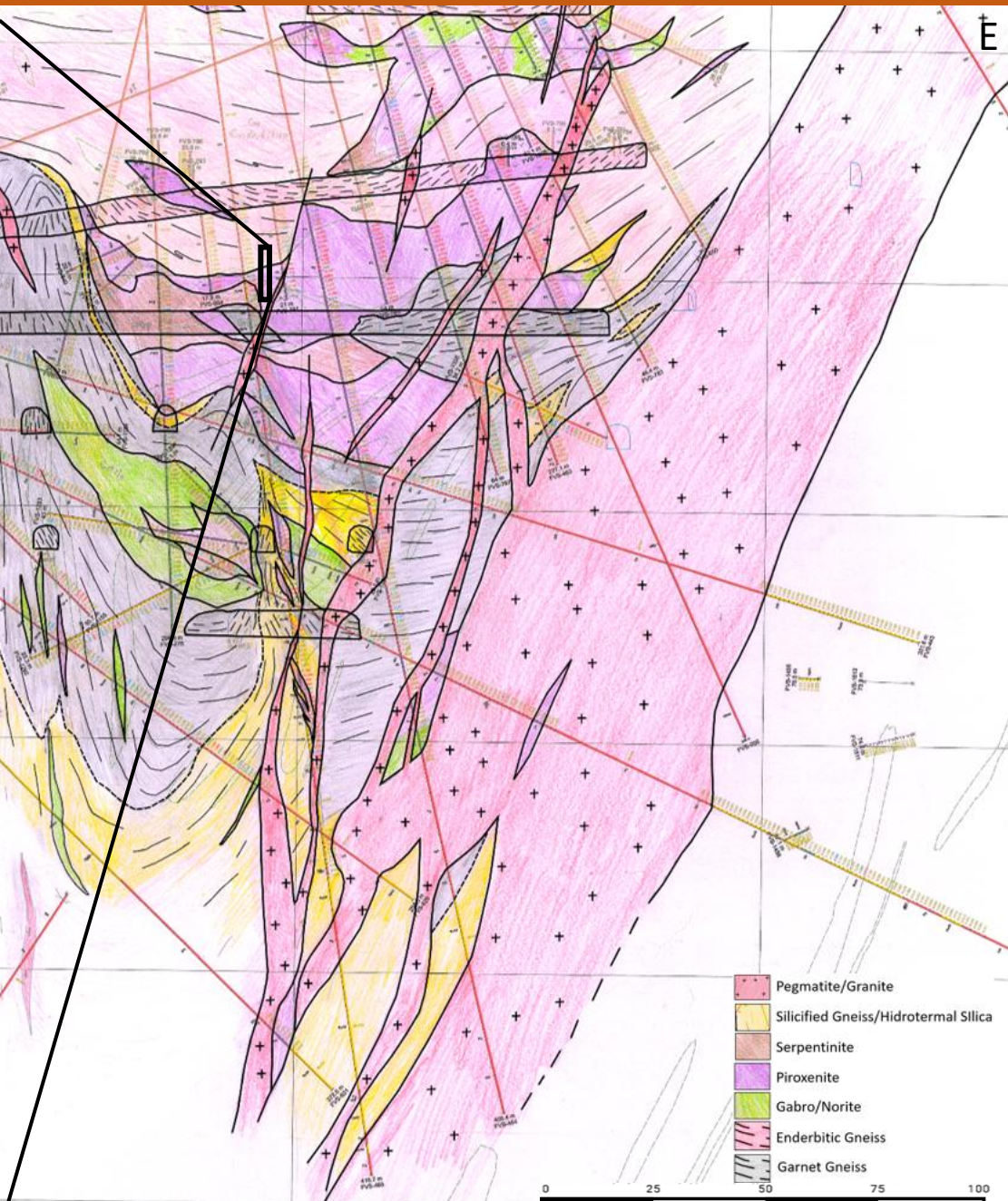



Feições na mina – Diques Discordantes (upper Tobogan)

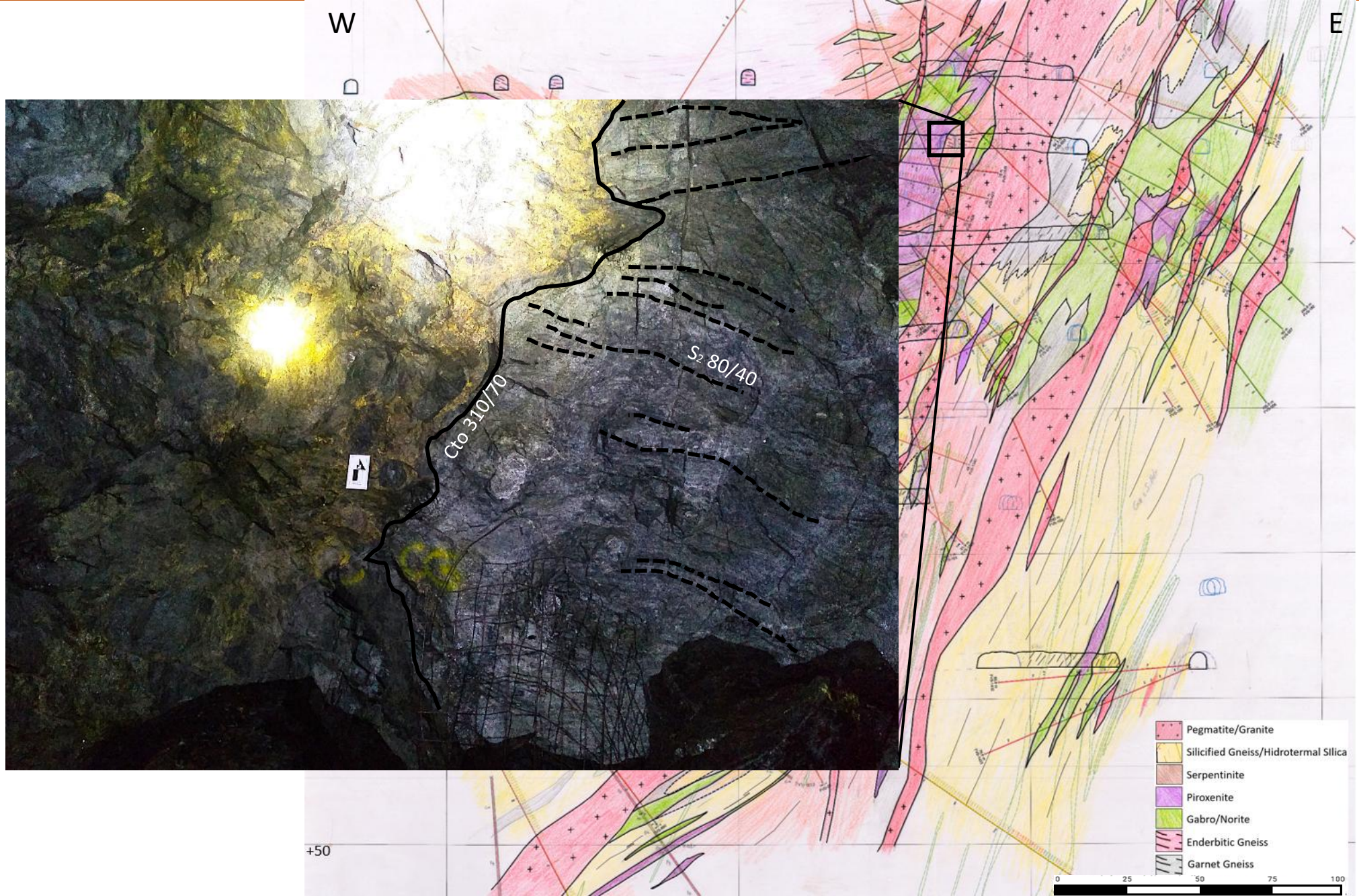

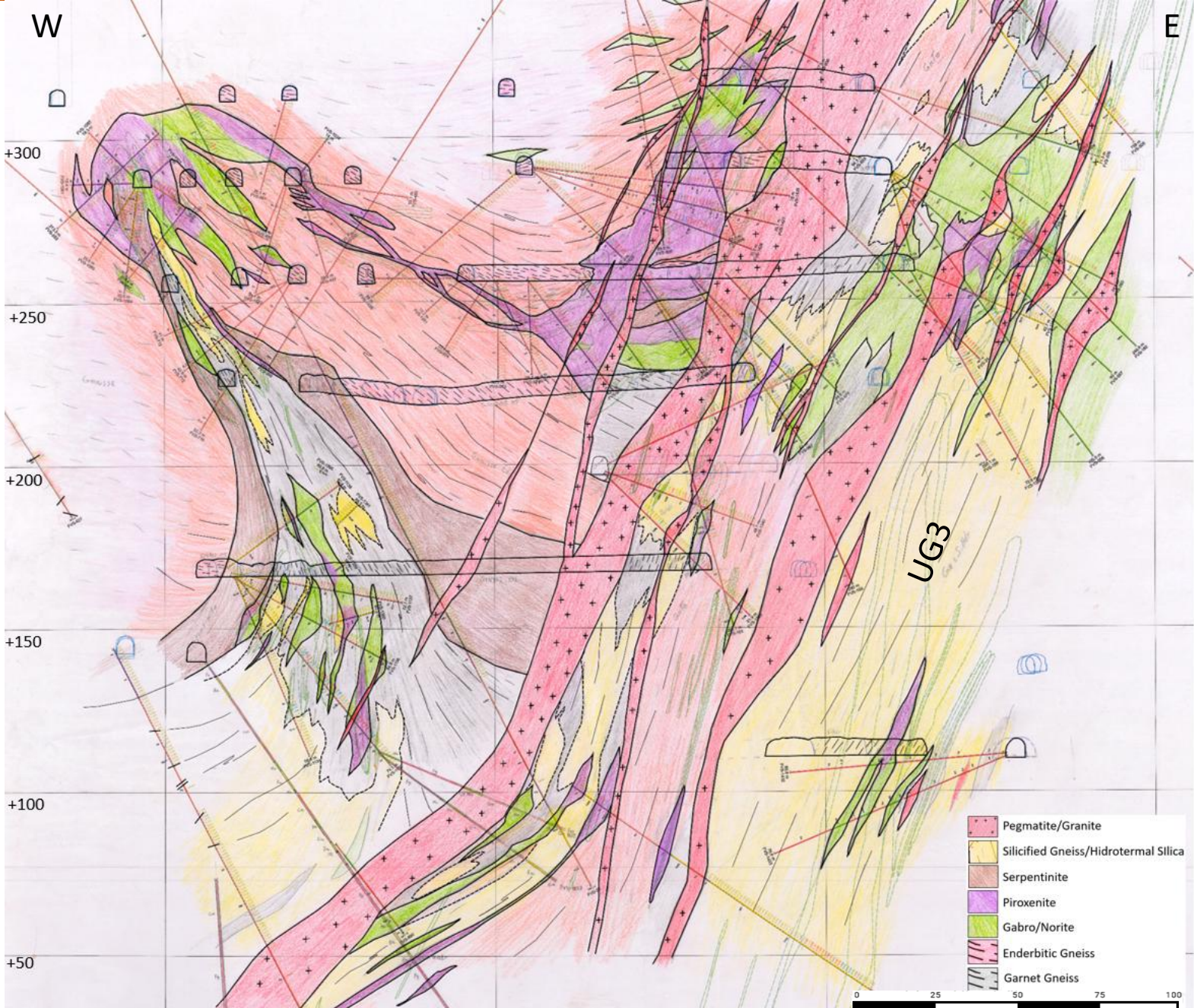

UG3 – Feições na mina (UG3)







Sombrero/Tobogan

Country Rock Foliation

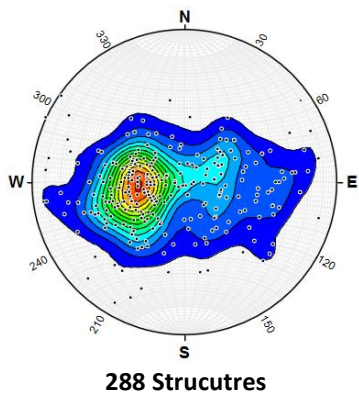

Ore contacts

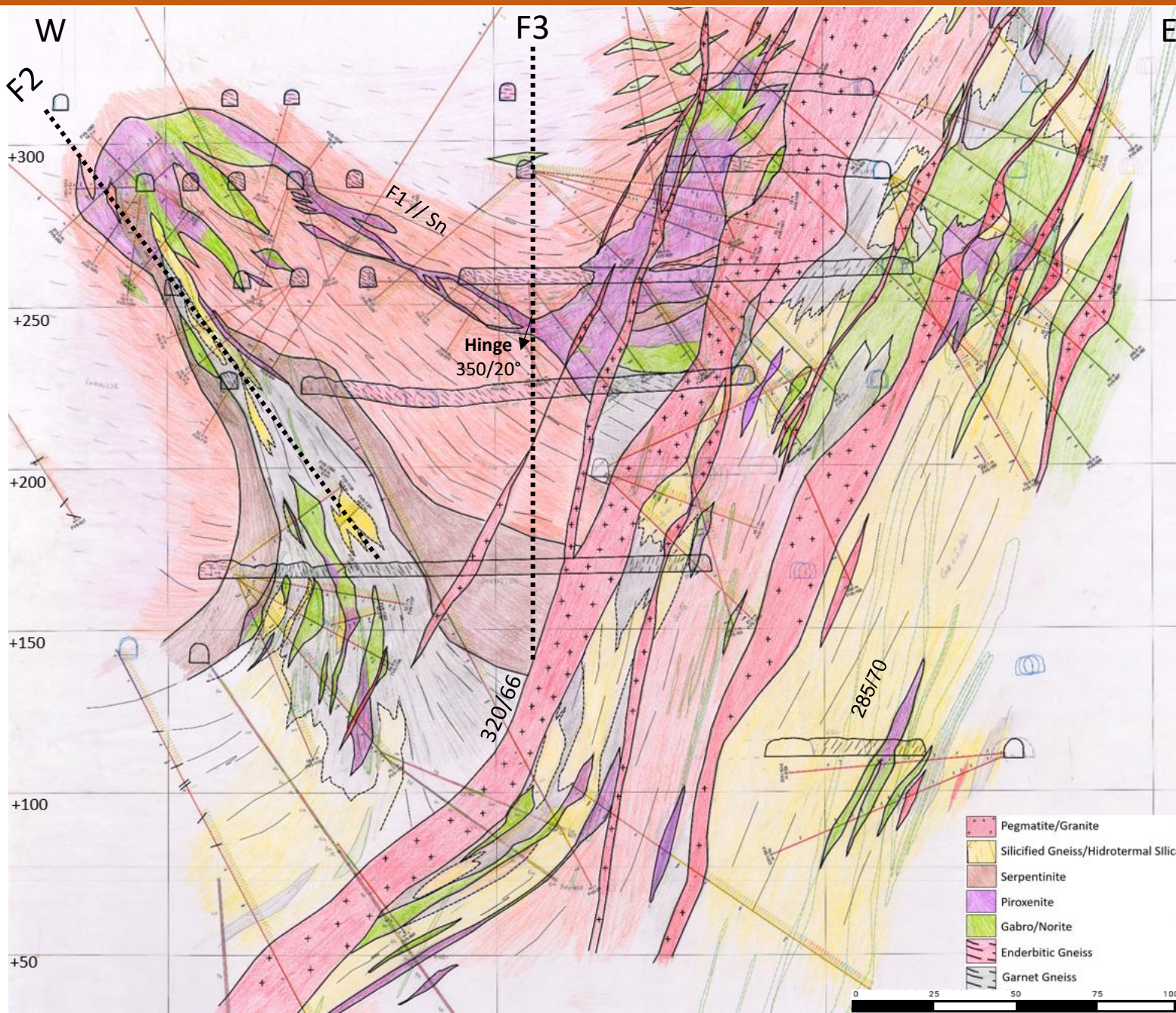
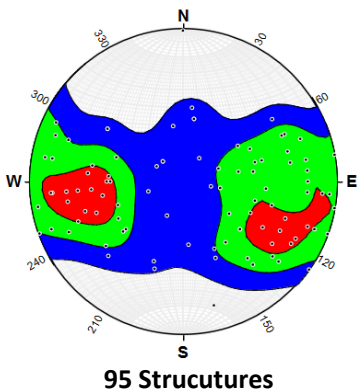

UG3

Foliation UG3

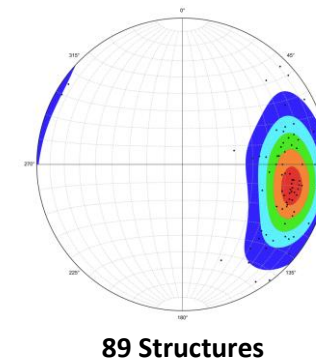

Ore contacts

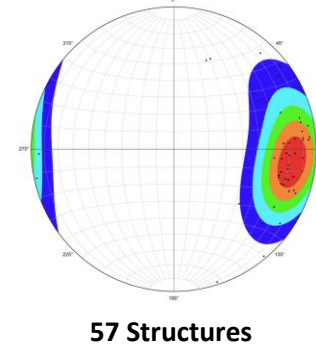



Bellow Tobogan

Country Rock Foliation

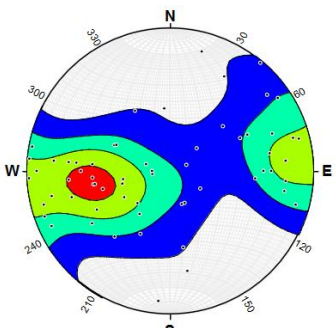

62 structures

Ore contacts

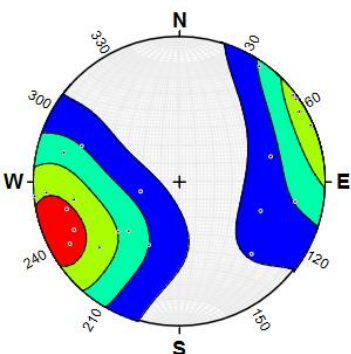

22 structures

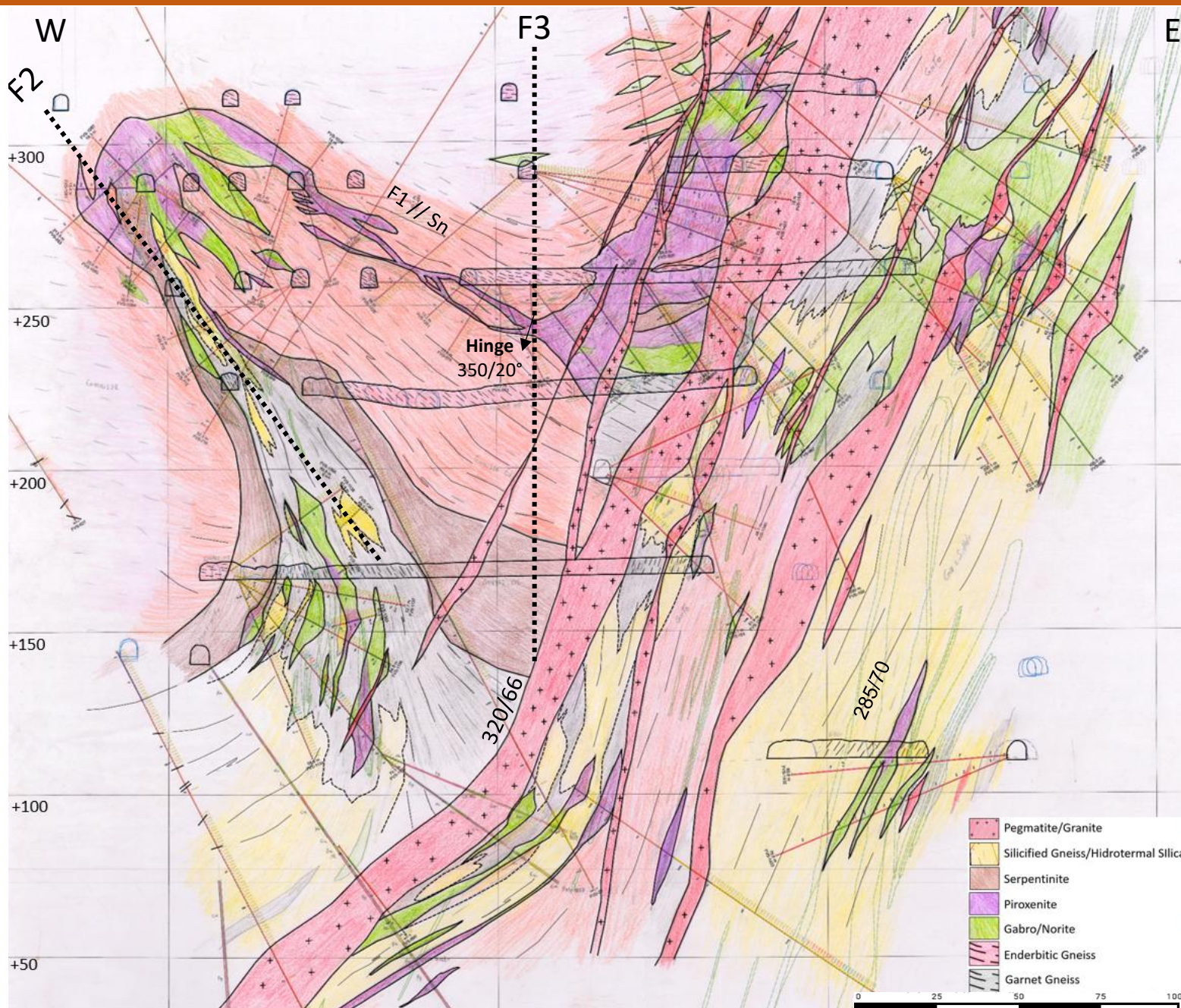

Faults

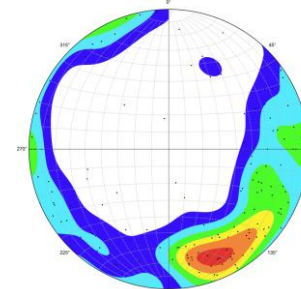

159 structures

Shear Zones

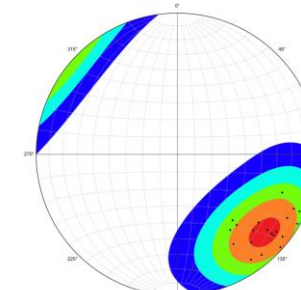

23 structures

Pegmatites/Granites

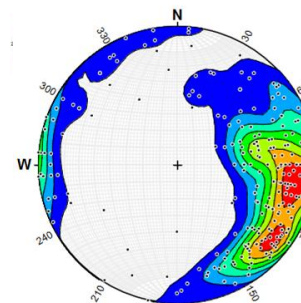

256 structures

Feições análogas em depósitos próximos

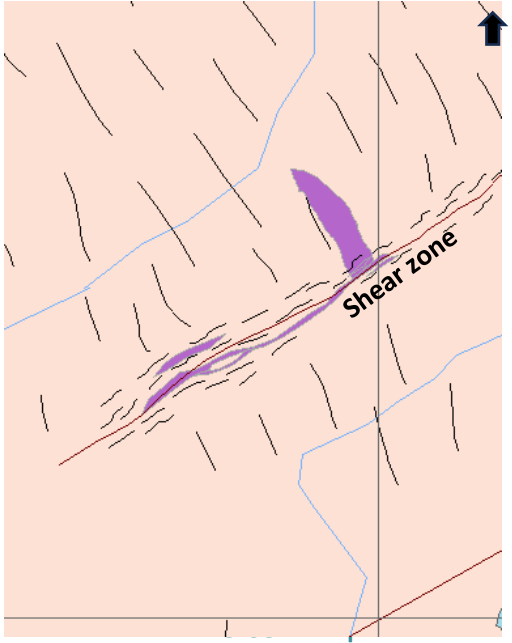
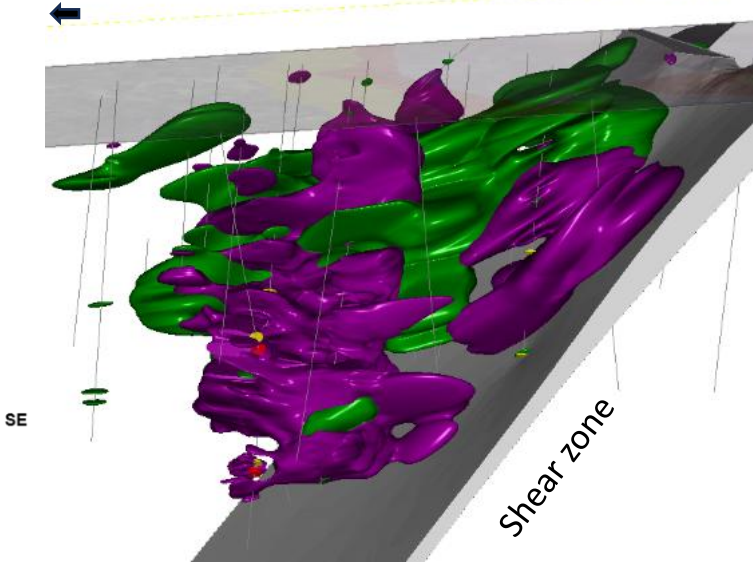
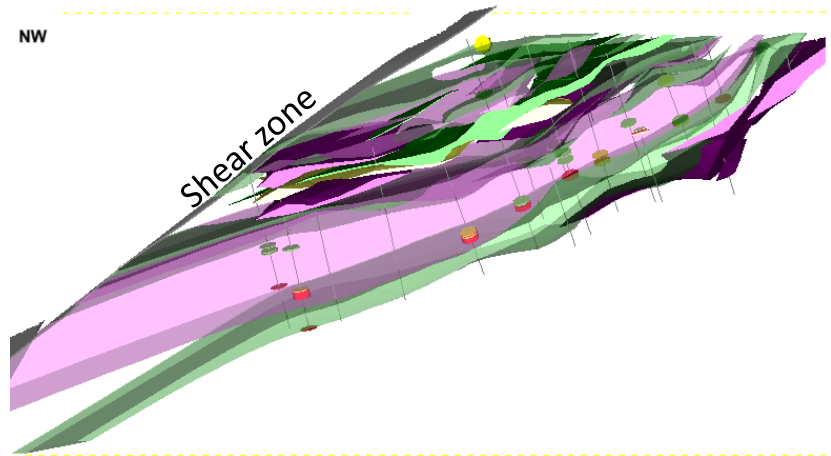
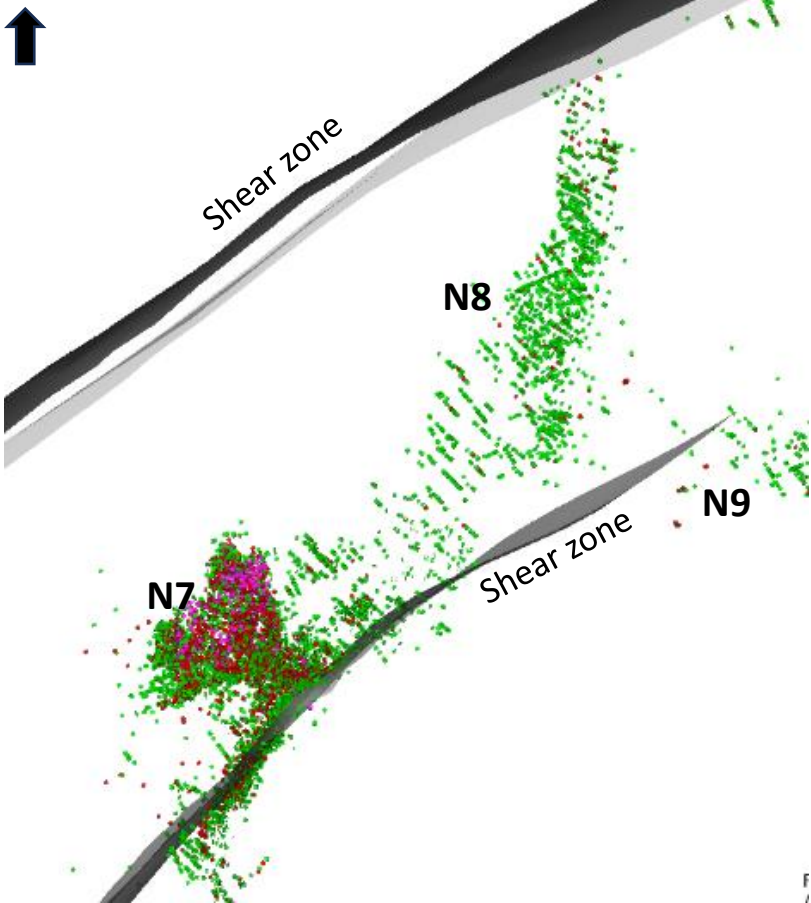

Mecanismos similares a saddle reefs?

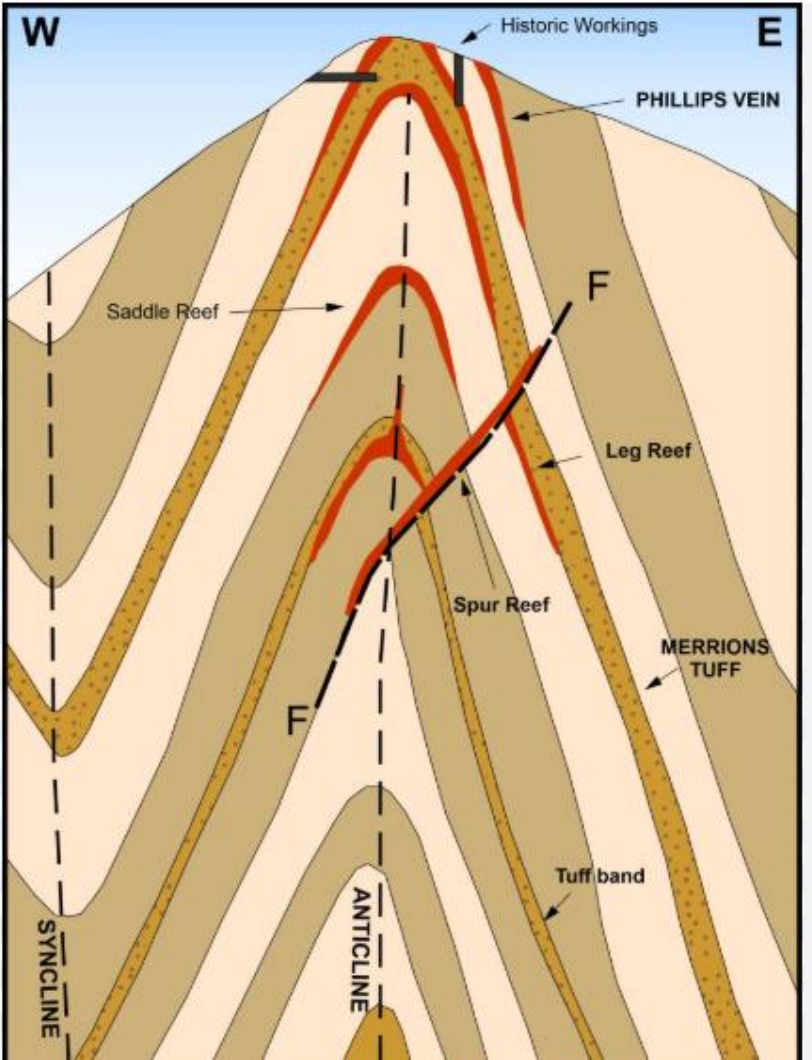
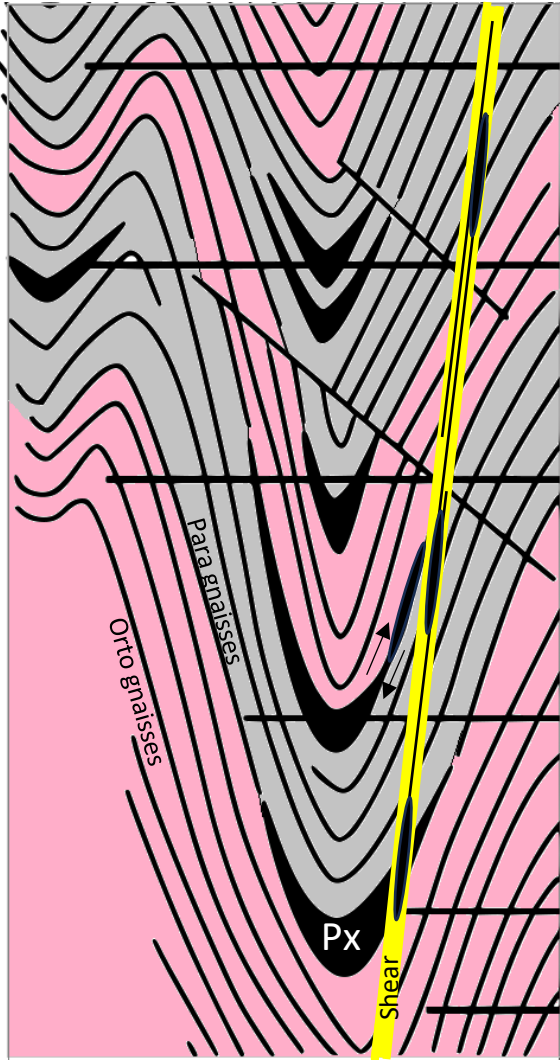

<https://www.goldendeeps.com/projects/tuckers-hill-gold/>



Minério entre unidades para/ortoderivadas?

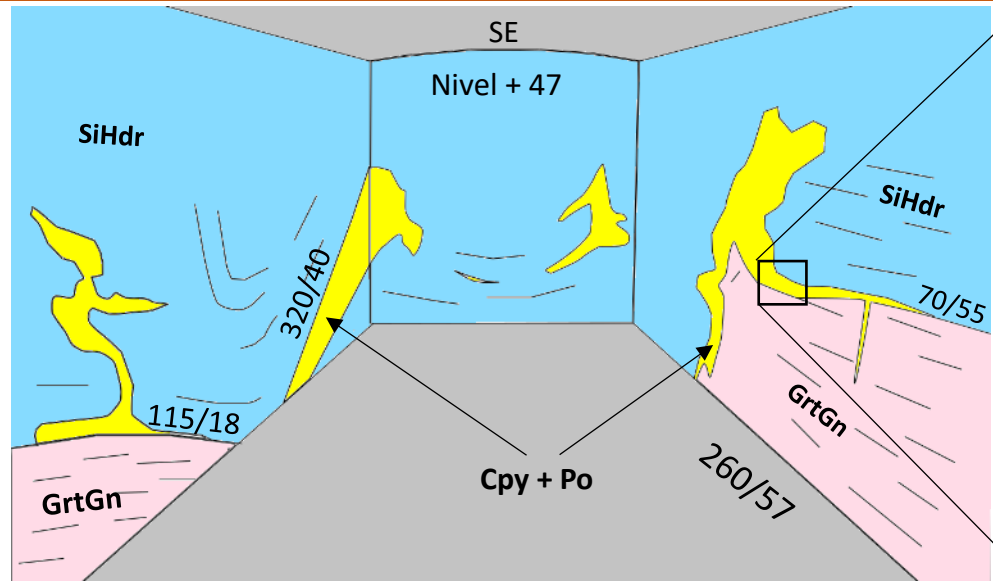

▪ Fatos:

1 - Parte do minério encontra-se **concordante** ao sistema de dobramento do embasamento.

- Ausência de evidências de que os piroxenitos tenham participado das sucessivas fases de deformação regional.

2 - A parte da ultramáfica mineralizada encontra-se **encaixada** em **zonas de cisalhamento**.

- Podendo apresentar sinais de deformação, além de expressiva alteração hidrotermal (em sílica principalmente).

▪ Hipóteses:

- As zonas de cisalhamento são as **estruturas profundas** que permitiram às **ultramáficas ascenderem** ao nível crustal em que foram alojadas, permanecendo ativas por longos períodos, **deformando e alterando** hidrotermalmente os litotipos encaixados.

- Zonas de cisalhamento também podem ter sido responsáveis por **reativarem** localmente planos entre as **unidades dobradas** (paragnaisses e ortognaisses), **abrindo espaço** para o alojamento das rochas ultramáficas em sistemas sills (além de diques). Nestas traps, as feições magmáticas originais permaneceram **preservadas**.

